

# ROPEYE LOOP

Ropeye Single Braid and Double Braid Loops are scientifically and practically tested and proven. These products provide stable quality and maximum durability for heavy loads.

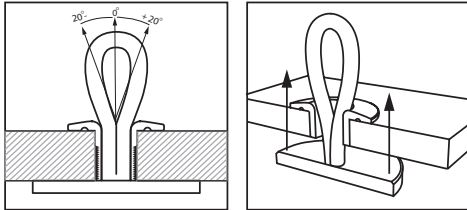

Ropeye Loop is designed for vertical loads with maximum loading angle of 20 degrees.

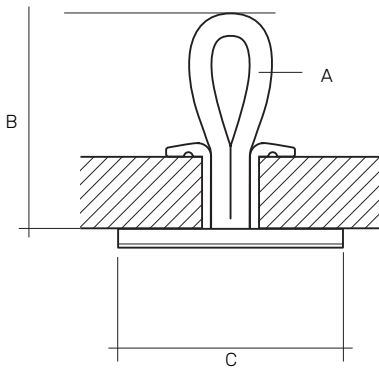

ROPEYE LOOP B-A	A Rope mm	B Loop mm	C Pad mm	Weight /g	Max Breaking Load kg	Safe Working Load kg	Suitable TDP for	
							*U	*C
ROPEYE LOOP 40-4	4	40	50	15	1900	800	TDP12	TDP14
ROPEYE LOOP 60-4	4	60	50	16.5	1900	800	TDP12	TDP14
ROPEYE LOOP 80-4	4	80	50	17	1900	800	TDP12	TDP14
ROPEYE LOOP 40-5	5	40	50	15.5	2900	1450	TDP14	TDP16
ROPEYE LOOP 60-5	5	60	50	16.5	2900	1450	TDP14	TDP16
ROPEYE LOOP 80-5	5	80	50	17.5	2900	1450	TDP14	TDP16
ROPEYE LOOP 40-6	6	40	60	27.5	3900	1950	TDP16	TDP18
ROPEYE LOOP 60-6	6	60	60	28	3900	1950	TDP16	TDP18
ROPEYE LOOP 80-6	6	80	60	30.5	3900	1950	TDP16	TDP18

**NB!** ALL PRODUCTS ALSO AVAILABLE IN GLASS FIBER

## INSTALLATION

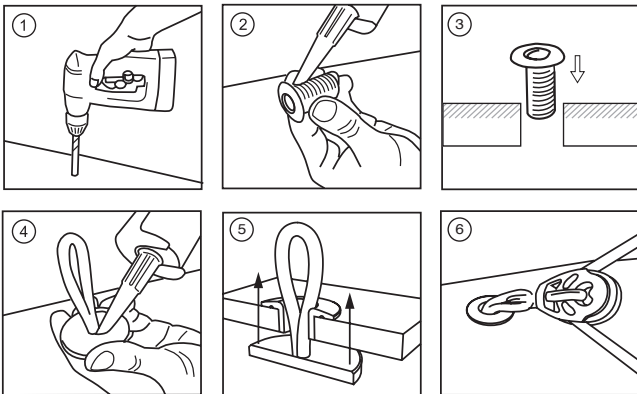

Drill a hole for the TDP. Clean the installation area with acetone to remove dust and grease. Apply Sikaflex 291i or other adhesive to make the installation watertight. Apply pressure to the product to secure it to the installation area. Attach the SLR to the loop. Wait 24 hours before putting any load on the product.

## ATTENTION

- DRILL THE INSTALLATION HOLE THE RIGHT SIZE
- LOOPS MUST ALWAYS BE USED WITH A TDP
- SLR USAGE IS RECOMMENDED TO AVOID PREMATURE WEAR OF THE LOOP
- REGULARLY EXAMINE THE LOOP FOR SIGNS OF DAMAGE
- DAMAGED LOOPS ARE UNSAFE AND MUST BE REPLACED
- DO NOT EXCEED SAFE WORKING LOAD

IF YOU NEED ANY HELP ON INSTALLATION SEND AN EMAIL TO:  
SALES@ROPEYE.COM

ROPEYE PRODUCTS HAVE A 2 YEAR WARRANTY



www.ropeye.com